



ELSEVIER



Journal of Power Sources 80 (1999) 190-197

Intermittent use of a low-cost alkaline fuel cell-hybrid system for electric vehicles

Karl Kordesch ^a*, Josef Gsellmann ^a, Martin Cifrain ^a, Susanne Voss ^a, Victor Hacker ^a
Robert R. Aronson ^b, Christoph Fabjan ^c, Thomas Hejze ^c, Josef Daniel-Ivad ^d

^a Technical University, Graz, A-8010, Austria

^b Electric Auto (EAC), Fort Lauderdale, FL, USA

^c Technical University, Vienna, A-1060, Austria

^d Battery Technologies, Richmond Hills, ON, Canada LAB 1C3

Received 10 November 1998; accepted 2 December 1998

Abstract

Alkaline fuel cell (AFC) hybrids with the capability to shut down completely between uses (by draining the circulating KOH electrolyte) can expect an operating life of about 4000 h, which is equivalent to 200,000 km of driving. They should be able to compete on cost with heat engines (US\$50 to US\$100 per kW). An early model is the hydrogen/air fuel cell lead-acid hybrid car, built by K. Kordesch in the 1970s. Improved air electrodes plus new variations of the bipolar stack assembly developed in Graz make success probable. In cooperation with Electric Auto (EAC), an ammonia cracker is also in development. A RAM[®] battery-ATC hybrid combination has been optimized. © 1999 Elsevier Science S.A. All rights reserved.

Keywords: Fuel cells/alkaline electrolyte; Zinc anode rechargeable cells; RAM cells; Applications /electric vehicles

1. Background

Fig. 1 shows the fuel cell city car which K. Kordesch operated on public roads for three years (Ohio license plate KK 358), demonstrating in the early 1970s that the life of the alkaline system with circulating electrolyte can be increased by shutting down the fuel cell, part of a hybrid system. Applying the experiences with the General Motors 'Electrovan' [11 (Electrovan 1967), which contained a 150-kW Union Carbide alkaline fuel cell (AFC) with liquid electrolyte and was operated on liquid hydrogen and oxygen, K. Kordesch built an air-breathing fuel cell hybrid car to be driven on public roads. The main idea was that only during actual driving time of the vehicle would the fuel cell be operational. This avoided open-circuit problems and electrode damage related to shunt currents. Furthermore, AFC-stacks use low-cost components, which could be replaced completely after years of service. In the car, the lead-acid batteries are mounted in the front; the hydrogen-air fuel cell system is in the rear of the vehicle [2,31]. The use of circulating KOH is advantageous for

thermal and water management. The exchangeability of the KOH makes it possible to operate on air with a less-than-complete removal of the CO₂. Incoming air was scrubbed with a soda-lime CO₂-absorber having a colour-changing pH indicator. Jet pumps can be used for a current-dependent gas circulation.

The early history of electric vehicle batteries and hybrids is well-documented [4]. Fuel cell types and performances are described in several books [5-7]. For reasons related to the requirements of space vehicles (e.g., 'no pumped electrolyte') AFC developments shifted to matrix cells. The European Space Agency (ESA) in projects with Dornier and Siemens as main contractors was to provide an AFC with immobilized electrolyte for the manned space vehicle HERMES [8]. New models and simulation studies of AFC's were made [9]. The firm ELENCO in Belgium, which had developed AFCs with circulating KOH [10] participated initially in the ESA program. The ESA project was cancelled in 1992, but ELENCO continued its efforts until 1996. ZEVCO (Zero Emission Vehicle Co.) restarted ELENCO's AFC production in Geel, Belgium. A 5 kW AFC-fuel cell hybrid was demonstrated during 1998 in London, within an Austin taxi, especially built for inner

* Corresponding author

0378-7753/99/\$ - see front matter © 1999 Elsevier Science S.A. All rights reserved.

PII: S0378-7753(98)00261-4



Fig. 1 (a) and (b): The Austin A40 hybrid city car

city use. A secondary battery (a high-power, spirally wound, lead-acid type) was used for peak power loads and for acceleration and could be also be charged from external power.

2. Operational data of the Austin A40 hybrid vehicle

The Electrovan used the fuel cell only for propulsion. The performance of this 150 kW hydrogen/oxygen sys

tem, when connected to a newly designed A.C. motor, provided a performance close to that of the comparable internal combustion engine van (which did weigh 30% less). The Austin car used seven, series -connected lead acid batteries for supplying peak power during acceleration and hill climbing. Fig. 2 shows the electrical characteristics of this fuel cell hybrid. The take-over of the load is determined by the slope of the polarization curves. The 90 V, 6 kW, hydrogen/air fuel cell system with circulating KOH electrolyte and the necessary accessories are shown

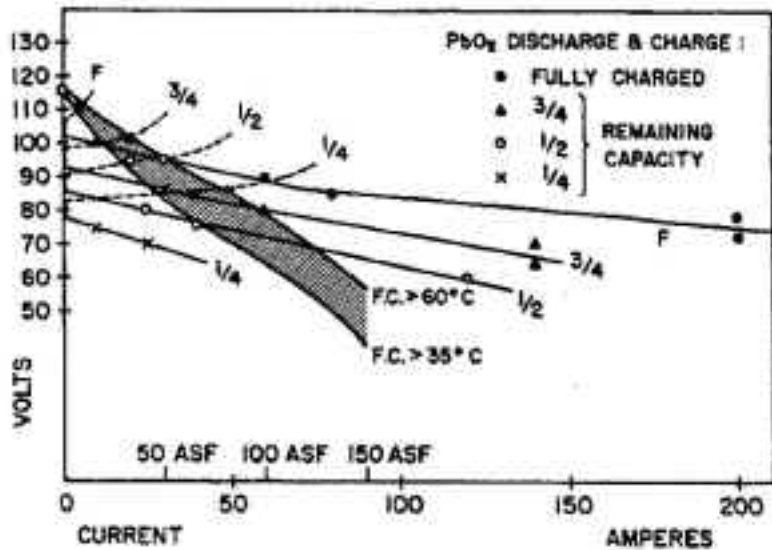

Fig. 2. Voltage and current characteristics of the fuel cell hybrid.

in Fig. 3. The complete hybrid propulsion and control system of the Austin car is presented in Fig. 4. No d.c./d.c. power converter was used.

The whole system was fitted into the Austin A40, whilst keeping it as a four-passenger car. It weighed 730 kg before and 950 kg after the conversion. Six lightweight pressurized hydrogen tanks mounted on the roof contained the hydrogen for driving about 300 km in the city and these could be refilled in 2 min using quick-connection hoses from a hydrogen tank farm. The life expectancy of AFCs with circulating electrolyte definitely increased by emptying the electrolyte from the battery between operating periods. Shutting off the hydrogen gas exposed the negative electrodes to air (which had a catalyst-regenerative effect) and a nitrogen atmosphere was finally established. This shutdown also eliminated all parasitic currents.

Advantages of this system were: The vehicle could be driven immediately after turning the key. The correct polarity of all the cells in the series chain was assured during start-up. No cell reversals! Safety-a primary concern. Nitrogen from a small tank was used for an intentional or automatic flushing of the system if a critical condition, such as an accident, was encountered. The six hydrogen tanks (each weighing 13 kg) contained a total of 25 m³ of hydrogen at a pressure of 150 bar. This is equivalent to 45 kW h (at 0.7 V per cell). The car used an average of 6 kW in the city (stop and go traffic), but less than 5 kW on the open road at 60 km h⁻¹. The specific energy of the fuel cell system (weight, including the gas cylinders: 250 kg) was 140 W h kg⁻¹. The calculated efficiency was about 60%. - Operating at high speeds took capacity from the lead acid batteries which could be replaced by the fuel cell during idling periods. Fig. 2 shows clearly how the temperature of the fuel cells and the state of charge of the lead-acid batteries determined the performance. The balancing of

the two systems is a matter of economy vs. performance. The lead-acid batteries used in the vehicle were standard 12 V SLI types. The total battery weight was 150 kg. The short-time peak current output was up to 400 A. At that time (1970) the SLI battery life was not satisfactory, but industrial type lead-acid batteries could not supply the peak loads. The combined weight of fuel

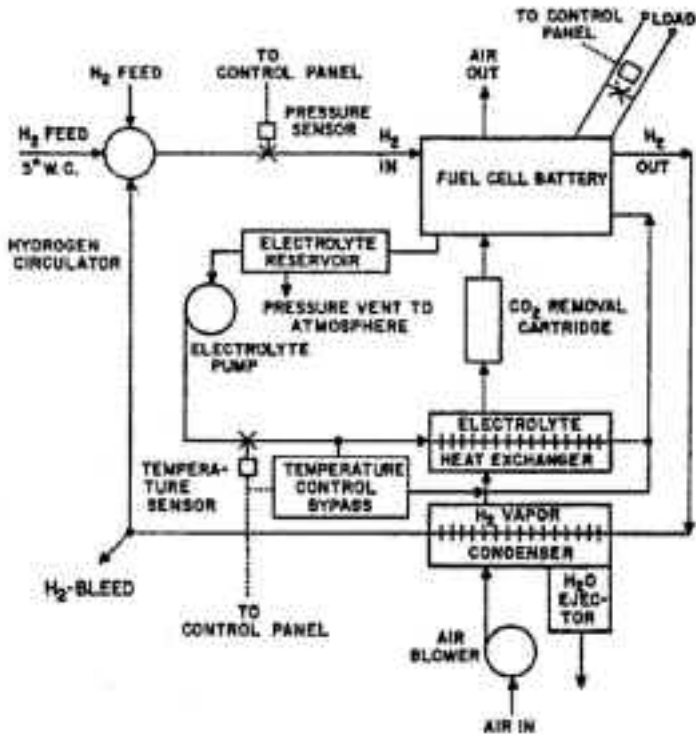

Fig. 3. The 90 V, 6 kW alkaline fuel cell system.

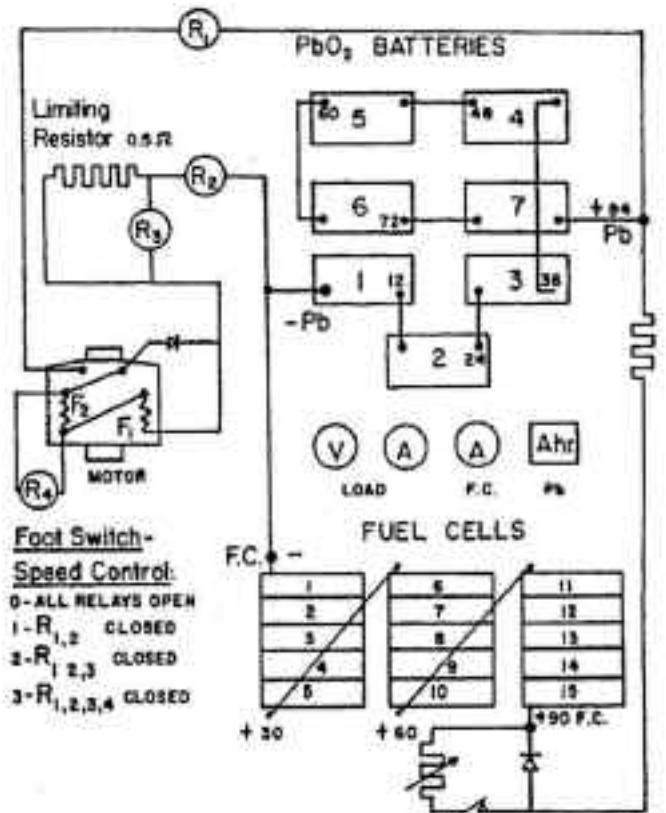

Fig. 4. The Alkaline fuel cell-lead-acid battery hybrid.

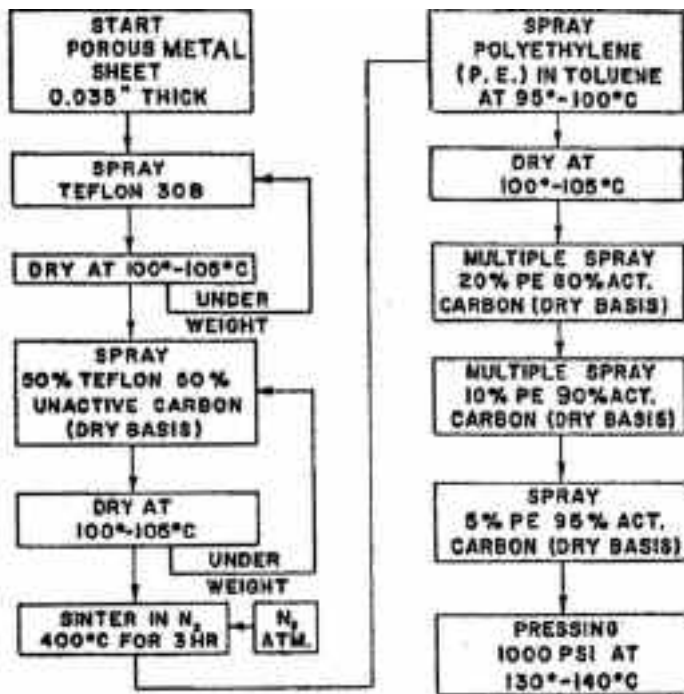

Fig. 5. Flow chart for the manufacture of spray-type Teflon-carbon electrodes.

carbon on porous Ni plates as described in UCC patents and publications [11]. They were called type T-2, replacing the 1/4-in. porous carbon electrodes (T-1) which Union Carbide (UCC) produced earlier for US Navy Systems and for a 90-kW Ford Motor Co. experimental fuel cell.

A 1975 UCC version, the T-3 'reversed' electrode was not available at the time when the Austin was built. The T-3 electrodes represented better oxygen (air) electrodes with a far longer life at high currents and they could also be used for regenerative fuel cells or rechargeable zinc/air cells [13].

Figs. 5-7 show different methods of manufacturing porous carbon electrodes which were further developed during several dissertation projects in Graz [5,71].

Fig. 5 shows the Teflon-PE-carbon spray production process, originating at UCC. Fig. 6 shows the electrode production with acetylene black and sugar as the filler material. Fig. 7 shows a production method for carbon electrodes with Vulcan Black and ammonium carbonate as the filler.

cells and lead-acid batteries was 400 kg, more than the desired one-third of the curb weight of the car. The permitted loading was still 320 kg. Regenerative braking and special radial tires were removed after some initial testing. The minimum temperature which assured the water removal balance up to 100 mA cm^{-2} , was 70°C . At low loads (battery charging only) the 9 N KOH would concentrate up to 12 N. A separate 15 A charger was installed for charging from the 115 V line.

3. Electrodes

The electrodes of the Electrovan and of the Austin were from comparable T-2 production lots: thin, catalyzed

4. Designs of bipolar stack

The same types of hydrogen and air electrodes, as used in the Kordesch car, were later tested at the Brookhaven National Laboratory at higher temperatures (up to 84°C) and it was found that the higher temperatures allowed current densities up to 150 mA cm^{-2} [14]. Unfortunately the ohmic resistance of the 400 cm^2 electrode cells with edge current collectors was high. This was a reason for the development of the bipolar electrode assemblies at the Hydrogen Institute in Canada [15] and at the Technical University in Graz, Austria [16]. Fig. 8 shows the typical construction. In a bipolar stack the current density over the electrode is uniform and far higher terminal voltages are achieved. An operating 'window' of $50\text{-}200 \text{ mA cm}^{-2}$

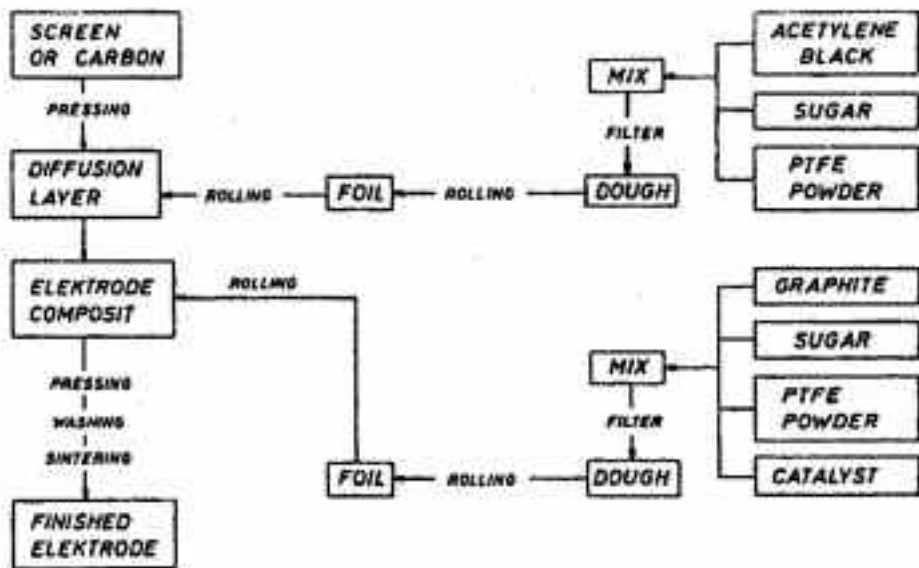

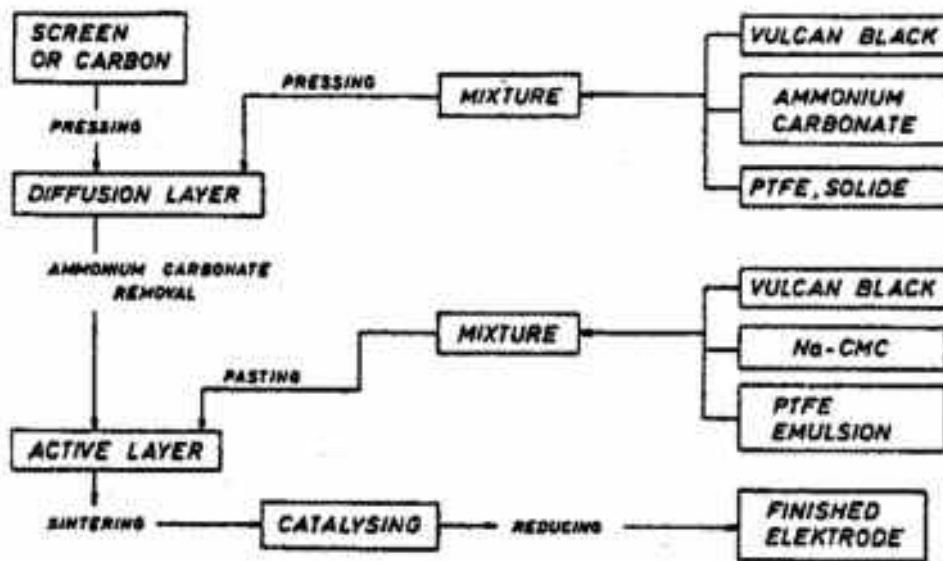

Fig. 7. Production of electrodes using Vulcan black.

between 0.85 V and 0.80 V is desirable for high efficiency. The literature describes also another bipolar fuel cell design, the Alstom OXY System [12]. This design can be improved with metal instead of carbon foils.

5. Fuels for electric vehicles

5.1. Reformer fuels, hydrides and liquid hydrogen storage

Methanol and hydrocarbons are candidates as reformer fuels. For AFCs the CO₂ content must be removed by a shift reactor, by a swing adsorption process, or by a new method, using sponge iron (see later). Unlike PEM cells, CO is no problem for noble metal catalysts on carbon in alkaline cells. The fuel storage can also involve the use of metal hydrides to act as a buffer until the reformer starts. Liquid hydrogen has been used too, but the liquification lowers the fuel efficiency by 30%. Only the Direct Methanol FC gets around the reformer problems. It could be the future competitor for reformer fuel cells. Interestingly, JPL also report a longer life (4000 h vs. 200 h) by intermittent usage.

5.2. Iron sponge

Iron sponge is a product of the reduction of iron ores and is used in steel furnaces for cooling purposes. It was H-POWER who suggested its use as a source of hydrogen (We plus steam produces clean hydrogen and iron oxide). Cycling tests with various iron sponges have proven the feasibility [17]. Fe sponge studies, especially for biogas upgrading, but also for simple shift reactions are being made at the Technical University of Graz (V. Hacker, Institute Prof. K. Friedrich).

5.3. Ammonia as a fuel for AFCs

Anhydrous liquid ammonia is an interesting carrier of hydrogen and its transportation in low pressure cylinders is a commercial practice. The specific energy is 3.3 kW h kg⁻¹. From this value, 15% was lost in a catalytic cracker, producing 75% hydrogen [181]. Fig. 9 shows an ammonia cracker built for US Army 500-W fuel cells. It operates at high temperatures on noble metal, nickel or iron catalysts.

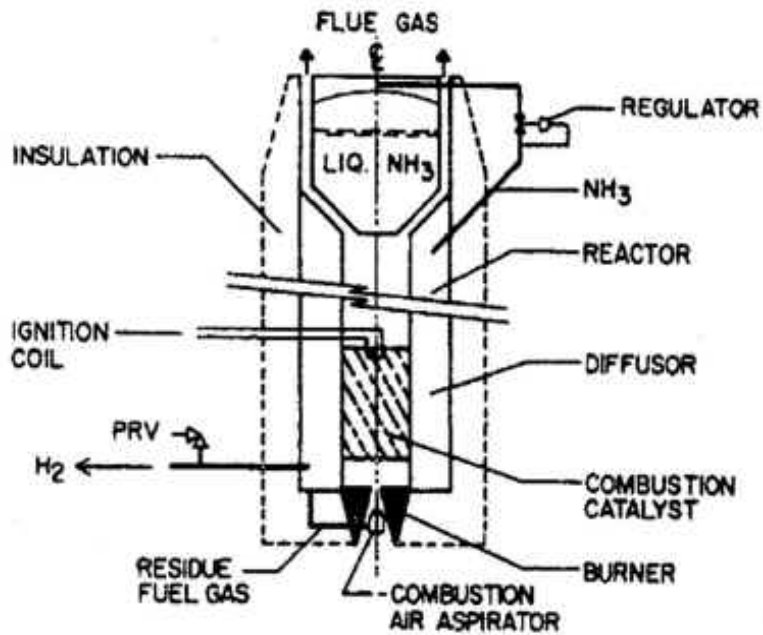
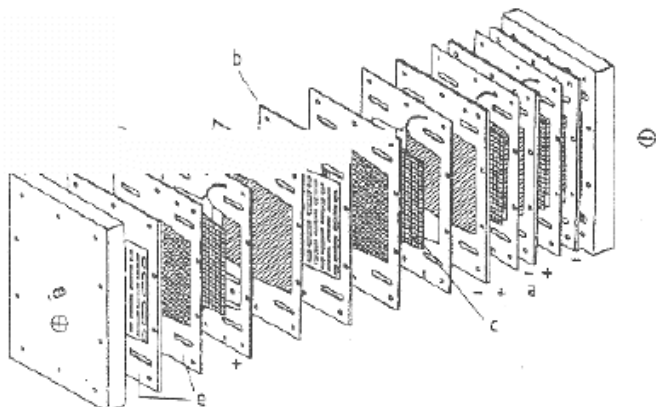

Table I

Projected performance of a hybrid system using a hydrogen/air alkaline fuel cell and a series/parallel array of improved rechargeable MnO_2 -Zn (RAMTM) cells, delivering 50 Wh kg⁻¹, 300 W kg⁻¹ and giving 500 charge/discharge cycles

Low temperature (350°C) crackers are also possible, and early designs with Raney-metal catalysts date back to the 1970s. Different constructions are now being investigated at the Technical University of Vienna (T. Hejze, Institute Prof. Ch. Fabjan). Ammonia is produced from natural gas via hydrogen and is inexpensive. The worldwide production of ammonia (for fertilizing and cooling) is near 100 million tons per year. Poisoning by ammonia is completely reversible (quite contrary to methanol, which causes permanent damage). Liquefied ammonia causes frozen-skin damages. The strong smell warns of ammonia leakages and makes the inhaling of dangerously high levels impossible.

6. The use of RAM batteries in a hybrid system

In 1994, it was suggested that the lead-acid batteries in the fuel cell hybrid system could be replaced by rechargeable alkaline manganese dioxide-zinc (RAMTM) batteries which show a remarkably high storage life even at high temperatures and are capable of producing high currents [19]. Recently, the so-called 'bundle configuration', an assembly of cylindrical cells in parallel and series arrays, was described [20]. This work showed that RAM could replace even Ni/Cd batteries in both power output and capacity. With the many difficulties encountered with nickel/metal hydride batteries at higher temperatures (no fast charging is possible above 45°C unless a cooling system is built in) more studies of high-power RAMTM batteries were made. Fig. 10 shows a parallel-series assembly of AA (R6-size) cells as designed to replace small 12 V lead-acid batteries as used on electric bicycles. The example is a five-parallel/ten-series cell arrangement (dimensions in inches) [21].

12-15 kW hydrogen/air fuel cell, weight	220kg
5 kW h rechargeable battery, weight	100kg ^a
Vehicle curb weight + 4 persons (or 2 + luggage)	500kg
150 kW h lightweight H ₂ cylinders, weight	150kg ^b
Hydrogen consumption per 100 km	1.5kg
Driving range of the vehicle at 75 km/h	300kg ^c
Efficiency of the system	60%
Acceleration, time from 0 to 70 km/h	10 s
Maximum speed	100 km/h
20-minute high power output	30kW
1 -minute peak power output	60kW
Fuel cell working temperature	69-90°C
Readiness of the secondary battery	instantly
Cycle life of the secondary battery	500 cycles ^d
Time to full output from the fuel cell	3-5 min
Actual operating life on intermittent duty cycles	4000 h
Maximum current density for the air electrodes	150 mA cm ^{-2 e}
Noble metal catalyst loading for each electrode	0.1 mg cm ^{-2 f}

^aThis assessment uses 5000 AA cells, each weighing 20 g, in an assembly of 50 parallel strings, each with 100 cells in series, probably formed from four blocks of 25 X 50 cells. The basis of this new estimate is that the average voltage of an AA cell is now 1.2 V at 1 A, with a capacity of about 1 Ah at the 1 A rate. The short circuit current from one cell is 14 A, which would provide the peak power quoted. (The use of AA cells recognizes the optimal design of the present cylindrical cells. Future thin electrode stacks with bipolar plates will give a further improvement. However, they may be more expensive than the very low-cost, mass-produced cylindrical AA cells. These can also be made double in length, so cutting the number in half and adding 20% more capacity.)

^b If liquid ammonia at low pressure is used, the energy output would double for the same weight.

^c Accordingly, the range with ammonia would increase to 600 km.

^d This is based on an average depth of discharge (DOD) of 50%.

^e The current density with bipolar fuel cells will rise to 200 mA cm⁻² which will result in stacks with a 15-kW output and higher power endurance levels.

^f Later, the noble metal catalyst will be replaced by a lower cost catalyst at the air side.

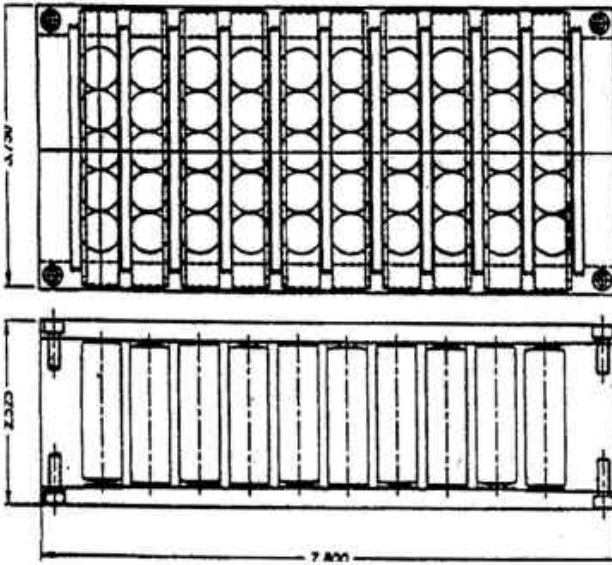

Fig. 10. Parallel-series assembly of RAM batteries (dimensions in inches).

In the light of these recent improvements, a table presented in 1994 is reproduced here (Table 1), with a high degree of confidence of this system being implemented during the ongoing fuel cell hybrid projects. It should be mentioned that the mass-production cost of RAM cells in the R6 size is far lower than that of Ni/MH cells. If the 1970 Austin hybrid car was built today, the performance presented in Table 1 could be expected.

7. Expectations from 'new' AFCs

- (a) The cost in mass production must be comparable to internal combustion engines (US\$50 to US\$100 per M).
- (b) The life expectancy must be sufficient to drive for 200,000 kin, (intermittent operation with complete shutdown possibility when the car is not in operation, is envisioned)

potential / mV

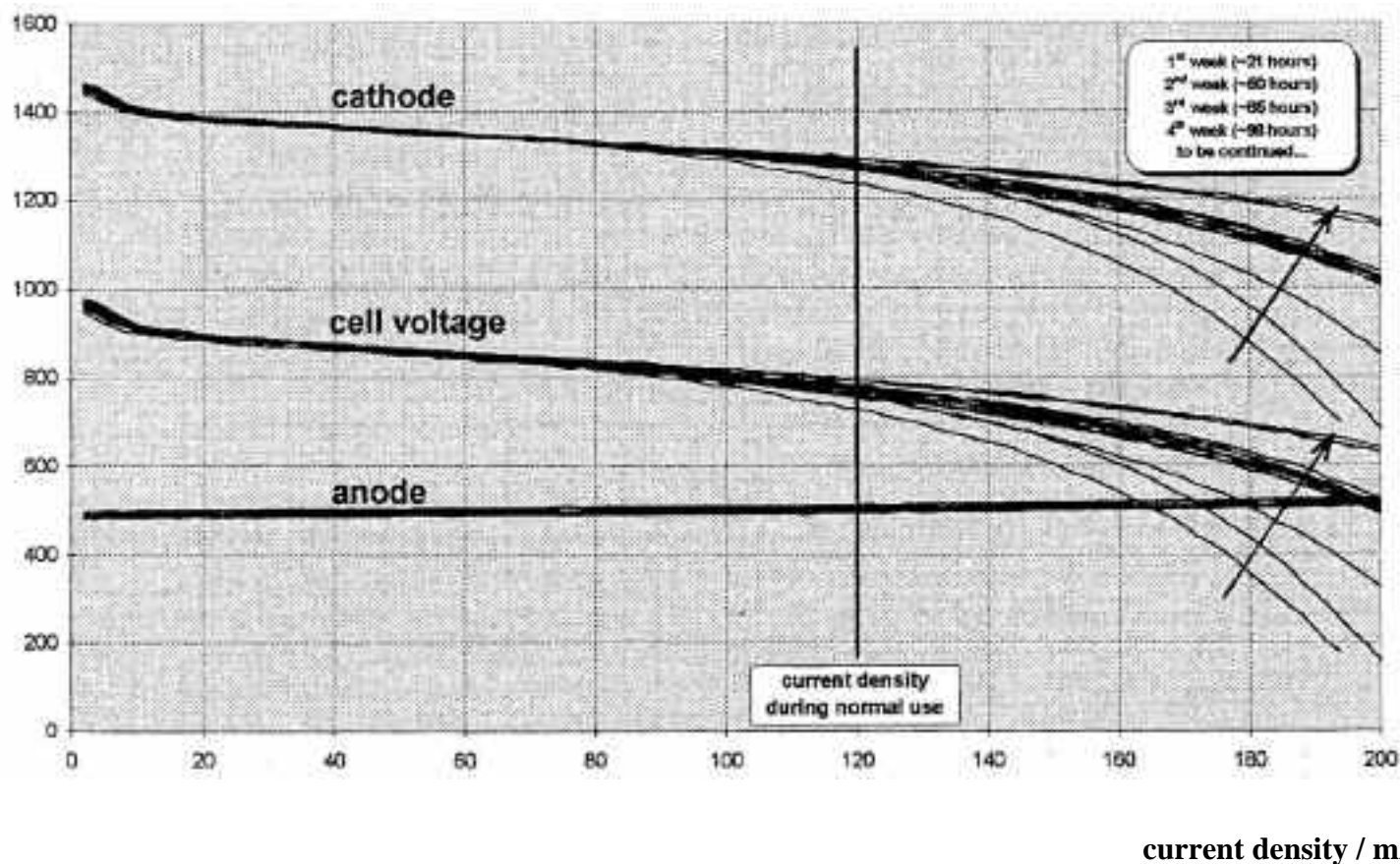

Fig. 11. Performance curves for a new type of electrode having improved stability of current output.

(c) The design of the fuel cell system must be such that its operation is fully automatic. Experiences with other large space-rated fuel cells from UCC and ESA will be utilized to model and simulate the hydrogen/air AFC vehicle system.

(d) The load capability should be sufficiently high (200 mA CM⁻²) to give a specific energy of 150 W h kg⁻¹ for the total system (without fuel tanks).

(e) New air electrode catalysts give choices of cost and performance.

Platinum is expensive, silver is costly or, good and inexpensive are the spinel or perovskite catalysts [22].

PEM and PAFC systems. However, it looks that the type of fuel cell to be used in street vehicles will ultimately be decided by economics. The fuel question is also of decisive importance for the application in an electric vehicle. Ammonia is globally distributed, may even be used in combustion vehicles as a gasoline additive to remove all NO_x traces from the exhaust gases (suggestion by Renault, 1998). In our laboratories in Austria and in the USA we are aiming to confirm the technical predictions and economic cost assumptions for manufacturing vehicle AFC hybrid systems. The use of RAM[®] Batteries is also being extensively tested.

Electric Auto Co. is preparing for the mass production of improved lead-acid batteries, similar to

A new type of electrode which has a much better performance and an improved stability is shown in Fig. 11. The curves for the air electrode especially indicate that the wetting-in process is improving the voltage level with operating time, reaching a good current density of approximately 200 mA CM⁻² after only 100 h of simulated vehicle operation (each curve represents a 5 h per day, 5 days a week operation), and still improving (top curve). The anode (oxygen) curves do not show any change with time, their current density extending far beyond a 200 mA cm² capability.

8. Outlook and conclusions

The feasibility of electric vehicles operating on fuel cell power plants is a technological fact. Present tests are using

their proprietary 'tripolar battery', for diesel or gasoline-hybrid systems.

Acknowledgements

Support of these studies is provided by Electric Auto, Fort Lauderdale, FL, USA. Battery Technologies, Canada, supplied RAM"-Bundle Battery test results. System Simulation hybrid models are being studied and evaluated by AVL, Graz, Austria.

References

- [1] The G.M. Electrovan, SAE-Papers 670176, 670181 and 670182, Detroit, 1967.**

2. K.V. Kordesch, Union Carbide, Parma Res. Lab., CRM 244, Aug. 11, 1970.

3. K.V. Kordesch, City car with H₂ -air fuel cell and lead-battery, SAE-Paper No. 719015, 6th IECEC, 1971.

4. K. Kordesch, Lead Acid Batteries and Electric Vehicles, Marcel Dekker, 1977.

5. K. Kordesch (Ed.), Brennstoffbatterien, Springer Verlag, 1984.

6. K. Kordesch, J. Oliveira, Fuel Cells, Ullmanns Encyclopedia, Vol. A-12, VCH, Weinheim, 1989, pp. 55-83.

7. K. Kordesch, G. Simader, Fuel Cells and their Applications, VCH, Weinheim/Wiley, NY, 1996.

13. K. Kordesch, J. Gsellmann, B. Kraetschmer, AFC Performance, in: J. Thompson (Ed.), Power Sources 9, Academic Press, 1983.

14. J. McBreen, G. Kissel, K.V. Kordesch, F. Kulesa, E.J. Taylor, E. Gannon, S. Srinivasan, Proc. 15th IECEC 2, 1980, 889.

15. K. Tomantschger, F. McClusky, L. Oporto, A. Reid, K. Kordesch, Alkaline fuel cells with carbon electrodes, J. Power Sources 18 (1986) 317.

16. K. Kordesch, The advancement of FC-systems and spin-off battery technology, Phys. Chem. 94 (1990) 902-912, Bericht d. Bunsen.

17. G. Simader, Investigations about Iron Sponge, Dissertation, Tech. Univ. Graz, 1994,

18. P.N. Ross, Jr., Characteristics of an NH₃ - air fuel cell hybrid system for vehicular applications, Proc. 16th IECEC, 1981.

8. F. Baron, The ESA Hennes-Manned Space Shuttle, Space Power Conf., Graz, 1993.

9. R. Simon, Systemmechanische Simulation von Brennstoffzellen am Beispiel einer alkalischen Anlage mit immobilem Elektrolyt, Dissertation, Tech, Univ., Graz, 1992.

10. H. Van den Broeck, CEC-Italian Workshop, Taormina 1987, Brussels, 1988.

11. M.B. Clark, W. Darland, K.V. Kordesch, Electrochem. Technol. 3 (1965) 166.

12. A.T. Emery, The OXY H₂-Air Fuel Cell, Natl. F.C. Seminar, Orlando, FL, 1983.

19. K. Kordesch, Life Extension of Liquid Electrolyte Alkaline Fuel Cells by Operation during Vehicle Driving Time Only, Proc., Abstr. No. 136, Electrochem. Soc. Meeting, Miami Beach, FL, Oct. 9-14, 1994.

20. J. Daniel-Ivad, K. Kordesch, E. Daniel-Ivad, Rechargeable alkaline manganese dioxide-zinc batteries, 33rd Intersociety Engineering Conf. on Energy Conversion (IECEC 98), Colorado Springs, CO, 1998.

21. K. Kordesch, J. Gsellmann, R. Aronson, New aspects for hybrid electric vehicles with alkaline fuel cells, Proc. Abstr. No. 723, Electrochem. Soc. Meeting, Boston, Nov. 1-6, 1998.

22. Y. Shen, Studies of Perovskite Catalysts for Fuel Cells and Rechargeable MnO₂ Batteries, Graz, 1989.